



All decision makers including owners, contractors, and engineers must read and understand the following pages. Failure to follow the instructions and guides on the following pages will void all stated and implied warranties. We urge anyone reading this instruction guide to call us with any questions at (865) 397-2914 during East Coast business hours.

If additional copies of this guide are needed, they may be downloaded at;

<http://www.wardburner.com/ventingwiring.html>



Thank you for choosing Ward Burner Systems for your direct fire needs. The following pages contain both general and specific instructions for installation. Please call with any questions regarding installation.

**A Note to Burner Owners:** Thank You for your purchase. There are several contractors you will need for the completion of your project. Please make sure they are certified to perform the work they are contracted to perform and they, along with you, read the information contained in this brief overview. If they proceed without reading and understanding this overview, problems can easily arise. Do not proceed with construction suggestions or procedures you are uncomfortable with. When in doubt, please call us for guidance or recommendations. Please urge those working for you to call us with ANY questions. We are here to help and want to see you have a successful project. **Please read pg. 8 for legal notice.**

**A Note to Electrical Professionals:** Please read all of pages 5 & 6 of this hand-out. Assumptions should not be made about grounding your C610U-1 Intermittent Pilot Control. Ground not only provides a means of ignition spark, but also is part of detecting a rectified AC current that is measured in micro-amps. Improper wiring can cause failure to fire and shut-down issues. Please call us with any questions regarding wiring of the items we have supplied. Also, feel free to call if you have questions regarding the wiring of thermostats, controllers, and fans. If you are not trained and certified for this work, do not proceed. **Please read pg. 8 for legal notice.**

**A Note to HVAC Professionals:** The following pages contain basic venting instructions for natural draft flues. If vertical natural draft flues are not possible because of site constraints, please consult with us about the use of horizontal runs, vent sizes, Btu capacities, and blowers. Improper venting will lead to a number of problems including flame roll-out, burned wiring, and shut-down issues. The use of blowers may make skirt modifications necessary. If you are not trained and certified for this work, do not proceed. **Please read pg. 8 for legal notice.**

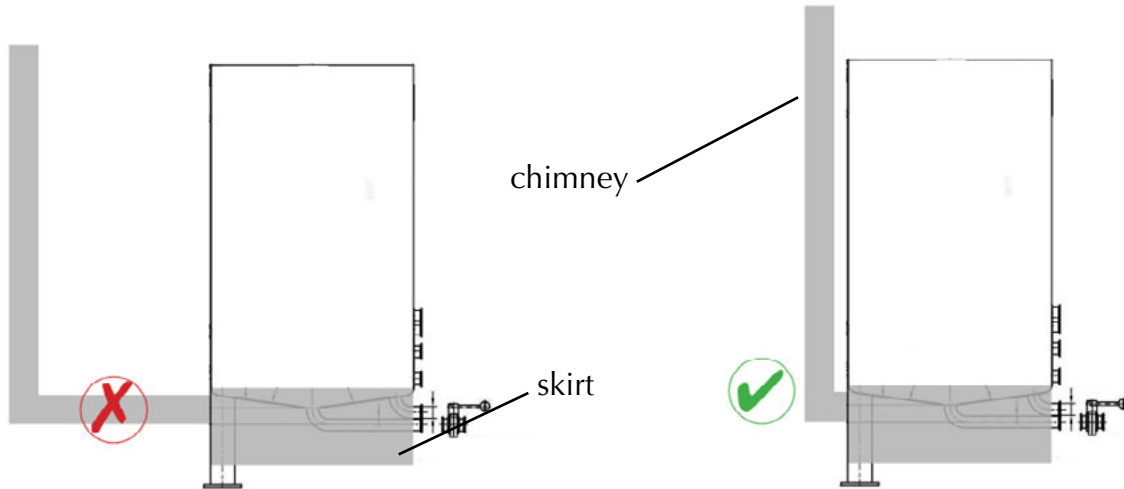

One of the most common problems that can greatly affect direct-fired tanks and kettles is improper flue design. The area under the pot is not an area that holds in heat... it is an area where heat transfer takes place. What goes in must come out. Restrictions that cause the flow of gases to slow or become minimized will cause slow heat ups, inefficient gas use, and unwanted shut-downs. If you cannot go straight up with your chimney, reduce horizontal runs as much as possible or put in 45 degree runs instead.

Burner tips should be placed 10-12 inches from the bottom of the pot.

Many skirts come with precut vent holes. The precut hole is the same as the size of interior of the flue pipe that should be run. In natural draft flues, NEVER reduce the size of the pipe to be smaller than the exit flue or choke down the flue pipe in a section of the flue pipe run.

The use "Type B" or "B Vent" materials should NOT be used for exit flues with these units and burners. We **STONGLY** recommend type "A" vent materials (UL 103 Standard or UL 103HT Standard) as initial exit temperatures will far exceed "B" vent material's stated temperature limits.



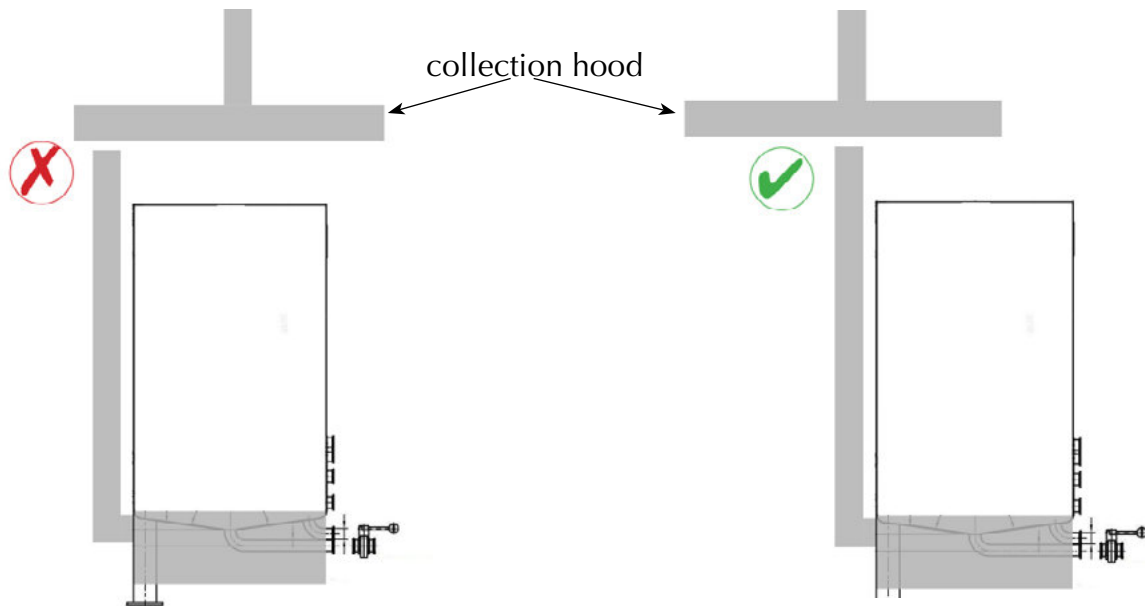

The exhaust for kettles and tanks should be centered under collection hoods if they are being used. The chimneys of hoods should follow the guidelines on these pages.



Make sure your exit flue is as high as possible

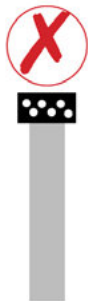

Chimney caps should not restrict the outflow of exhaust gases. Caps meant for residential wood stoves with spark arrestors are inappropriate for kettles and tanks. They are not designed to permit high flow.



The above venting guidelines are general and basic. Since every site and situation is different, these instructions are far from being complete. Please feel free to contact us for specific help and advice. Also, if your situation mandates horizontal runs or excessively short flue heights, please contact us as these issues will determine if you need to change vent sizes or install draft inducers. DO NOT run multiple flues into larger, single exhaust flues without consultation.

## Solenoid plumbing/wiring for 24volt intermittent pilot controllers

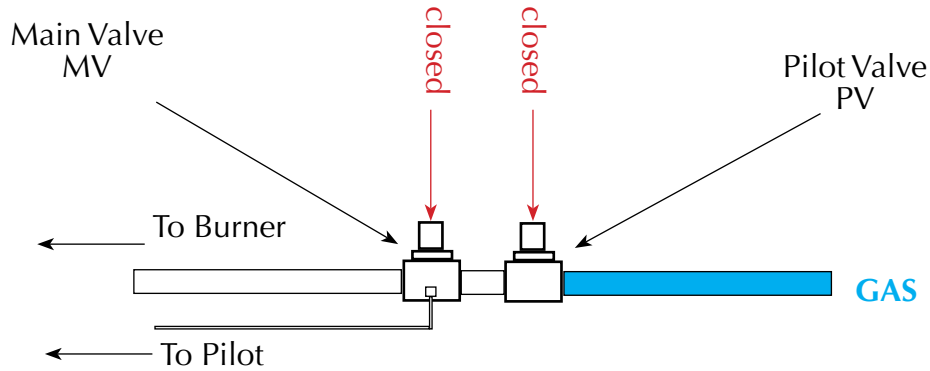

Many folks become confused by the valve names and how they are wired in the controller. This stems from the fact that the pilot gas must be taken from the main valve. Your valves are marked either MV (main valve) or PV (pilot valve). Please wire accordingly.

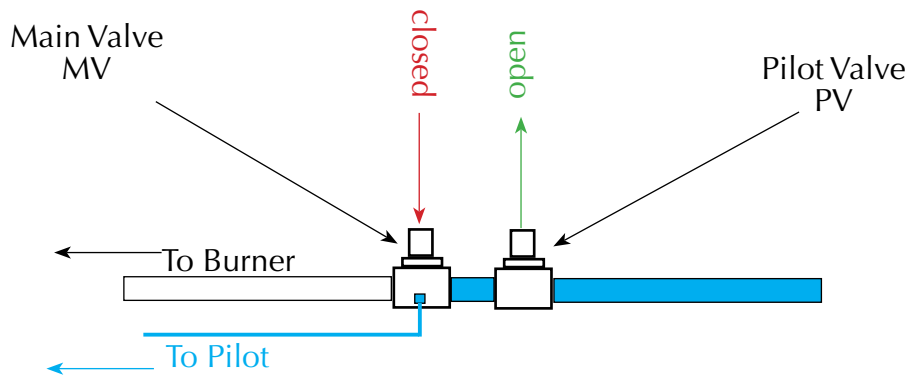

Once the pilot valve (PV) opens, gas passes through the pilot valve and into (but not through) the main valve. Gas then flows through to the pilot burner where sparking and ignition of the pilot burner takes place.

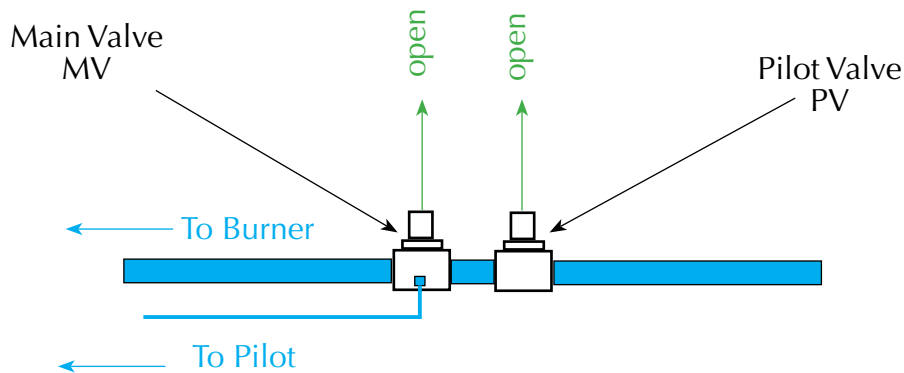

When the controller proves flame at the pilot, the main valve (MV) opens and gas flows to the main burner and ignites from the pilot burner.

**Do Not Remove Pilot Gas Supply from MV and Attach to PV.**

**Under No Circumstances Should Pilot Gas be taken from PV.**

## Wiring for your C610U-1 Intermittent Pilot Control.

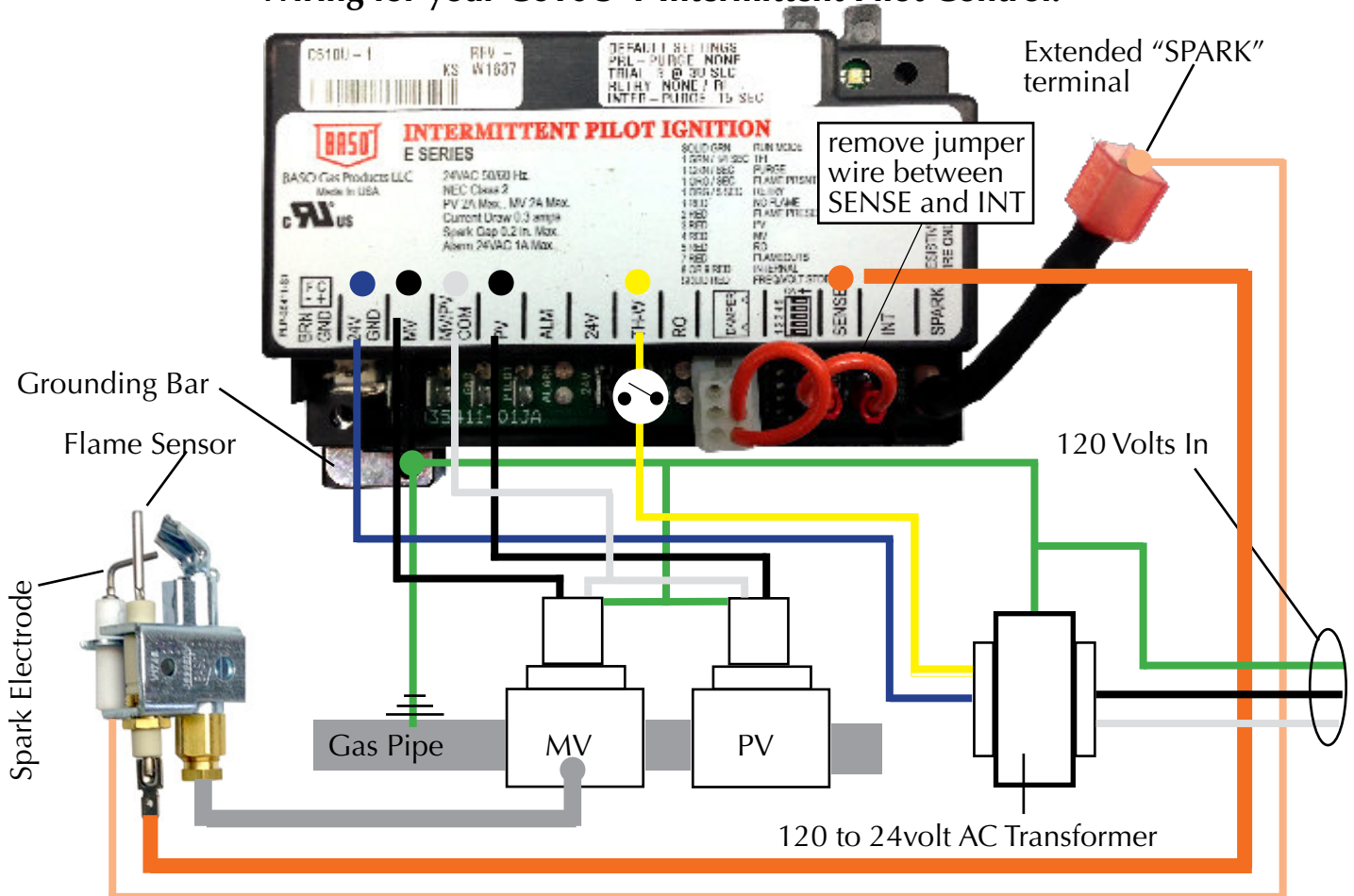

1. Your ground wire coming in from your 120 volt power supply should be spliced to your green wire coming out of the transformer. These then go to the grounding bar on your pilot control.
2. Run another grounding wire from the grounding bar to the gas piping outside the kettle skirt.
3. The Yellow wire from your transformer is attached to the TH-W terminal. (unless you are using a thermostat, in which case this is the wire to use to switch power on/off into the pilot control.)
4. The Blue wire from your transformer is attached to the 24V GND terminal.
5. The White wires (common) from your PV & MV valves are connected together and attached to the MV/PV COM terminal. The Green wires from the PV & MV valves are also connected together and connected with all green grounding wires to the Grounding Bar.
6. The Black wire from your PV valve is attached to the PV terminal.
7. The Black wire from your MV valve is attached to the MV terminal. (When using forced draft/ blowers, the Black wire from your MV may connect elsewhere. Follow blower instructions.)
8. The SMALLER orange wire from your Spark Electrode attaches to the SPARK terminal.
9. Remove the jumper that connects your SENSE terminal and the INT terminal.
10. The LARGER orange wire connects into the SENSE terminal. Please see special notes about this wire on the following page.

**NOTE:** Another item that is often overlooked concerns the larger **ORANGE** Sensing wire from the terminal marked "SENSE" to your pilot. **Do not run this wire in metal conduit alone or in any type of conduit with other wires. Do not zip-tie this wire to the metal parts of your kettle or piping. If you have to lay your orange SENSE wire over the metal components of your kettle or piping, insulate the metal with muffler tape or some other high-temp, nonconducting material. This wire should not be in direct contact with any of the grounded components. If the orange SENSE wire passes into a metal box, use a plastic cord grip or a nonconducting fastening method. Avoid having the orange wire touching other wires in the enclosure or have the orange wire coiled around itself. Shorten if necessary but, do not lengthen.**

Thermostats and controllers may be used to switch either the 120v power coming into your transformer or you can switch the 24v power coming out of your transformer at the TH-W terminal.

Draft inducers and blowers, such as the Tjerlund HS series, can also be wired into the control. Follow inducer and blower manufactures wiring diagrams or call us with any questions.

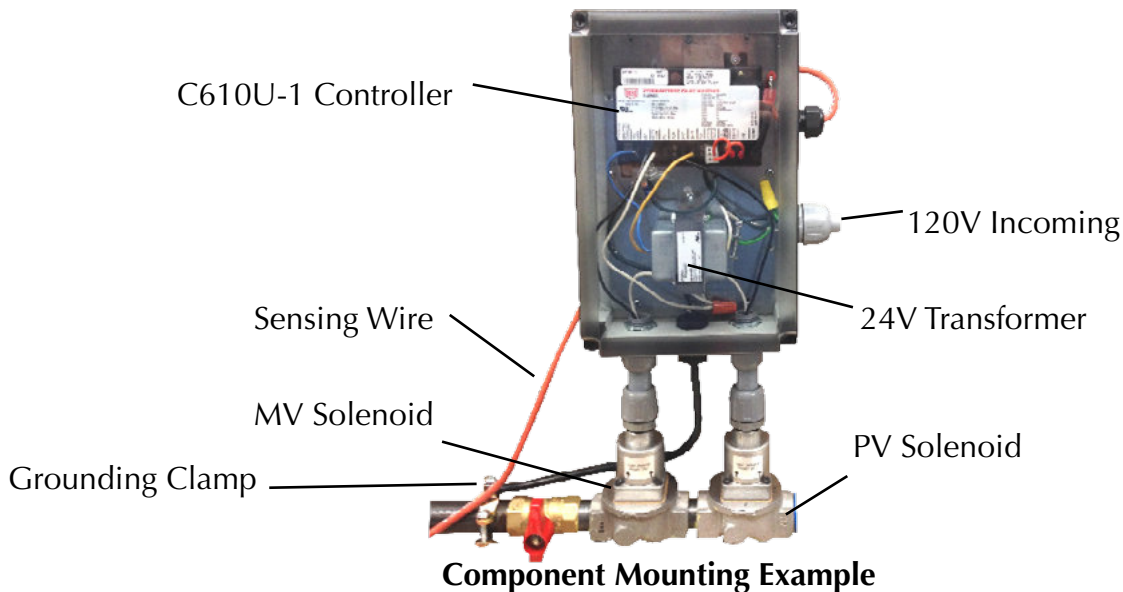

Above is an example of how your electric components can be mounted directly onto your solenoids. This is a 10" x 7" x 4" plastic water-proof washdown box with clear front and metal mounting panel. The clear front allows you to see "Status Lights" on the controller. Water-proof cord grips and conduit connectors provide protection from splash and wash down. This is an example. Components can be wall mounted and placed in different enclosures.

**Note: Your C610U-1 cannot be wired into a circuit that uses a GFI (Ground Fault Interrupter).**

**Please call the number below with ANY questions**

www.wardburner.com      email: info@wardburner.com  
PO Box 1086 • Dandridge, TN 37725      Ph. 865.397-2914



**Legal Notice.** Ward Burner Systems and its affiliates will not be liable for work performed by on-site contractors and/or their sub-contractors. Nor, will Ward Burner Systems and its affiliates be liable for any repairs made necessary by the work of said contractors and/or their sub-contractors. Failure of contractors and/or their sub-contractors to consult with us prior to and during installation will void any stated or implied warranties. All components provided by Ward Burner Systems and its affiliates are NIB (new in box) or newly installed by us on provided equipment. Ward Burner Systems and its affiliates will not be liable for damage to components caused by improper installation.

**Please call the number below with ANY questions**

www.wardburner.com      email: info@wardburner.com  
PO Box 1086 • Dandridge, TN 37725      Ph. 865.397-2914