

1. CONTINUOUS DUTY BLOWER	8. PILOT BURNER CLAMP	15. BASO SAFETY VALVE
2. SPARK IGNITION LEAD	9. MIXING TUBE	16. GAS COCK
3. PILOT AIR MIXER	10. GAS FEED	17. BLOWER SPEED CONTROL
4. VENTURI PILOT BURNER	11. PILOT BURNER GAS SUPPLY	18. SPARK IGNITION TRANSFORMER
5. SPARK IGNITION ELECTRODE	12. PRESSURE GAUGE	19. 120 VOLT GROUNDED LINE
6. THERMOCOUPLE	13. PILOT NEEDLE VALVE	20. FLOW CONTROL GATE VALVE
7. FLAME RETENSION NOZZLE	14. ELECTRIC SOLENOID VALVE	21. THERMOCOUPLE LEAD

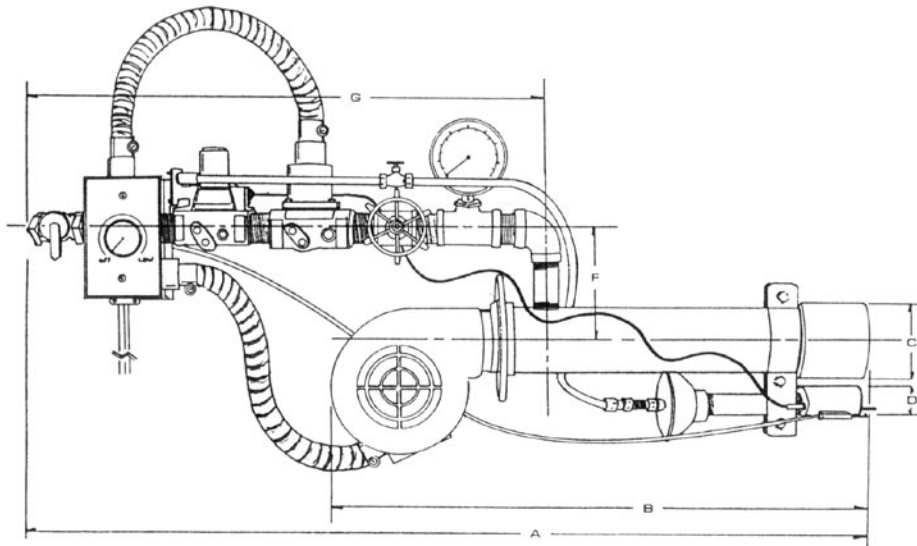

A. 34"	B. 20"	C. 3 1/4"	D. 1 1/2"	E. 5 3/8"	F. 5 7/16"	G. 22"
--------	--------	-----------	-----------	-----------	------------	--------

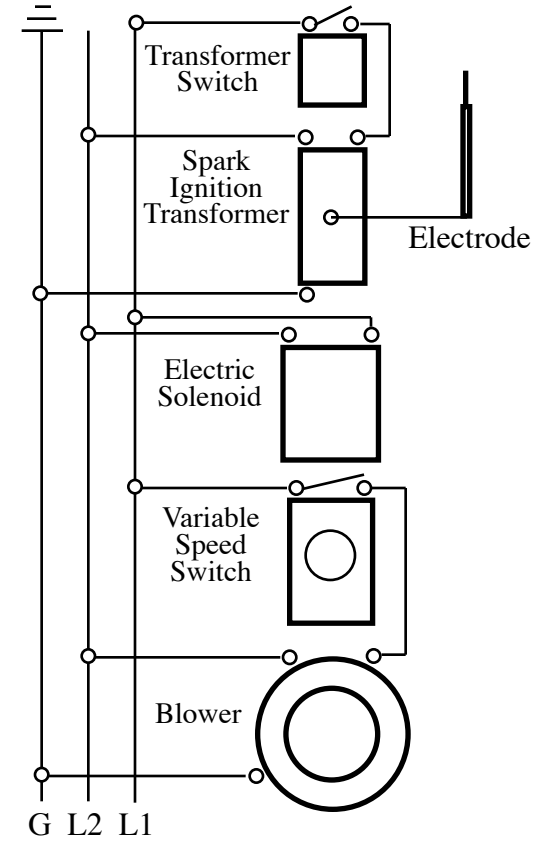

Wiring Diagram
120v

WARD
BURNER SYSTEMS

MB Series Power Burners